



TROTTER W 126

PRESSURE SENSITIVE LABELER

Labeler features robust construction with accurate and reliable operation throughout its long service life

Ideal versatile machine for pharmaceutical, cosmetic, personal care and household chemical applications, as well as contract packagers.

This servo motor driven pressure sensitive labeler is dedicated to wrap-around labeling of round containers. Handles a wide range of containers and label applications at speeds of up to 150 containers per minute.



FEATURES AND BENEFITS

- Wrap-around labeling of round containers
- Tool less changeovers
- Servo-driven label dispenser
- Label registration sensor
- PLC Controls
- Stainless steel open-frame design
- Speeds up to 150 cpm



OVERALL MEASUREMENTS

- Length: Base labeler 120" (305 cm)
- Width: 49" (125 cm)
- Height: 63" (160 cm)

STANDARD FEATURES

- Wrap-around labeling of round containers
- Tool less changeovers
- Servo-driven label dispenser
- Stainless steel open-frame design
- Stainless steel raised-bed conveyor
- PLC Controls
- Repeatable heavy-duty dispenser mount with digital adjustment
- Label registration sensor
- Rewind spindle
- 6" Touch Screen HMI Controls
- Brushless motors
- Speeds up to 150 cpm

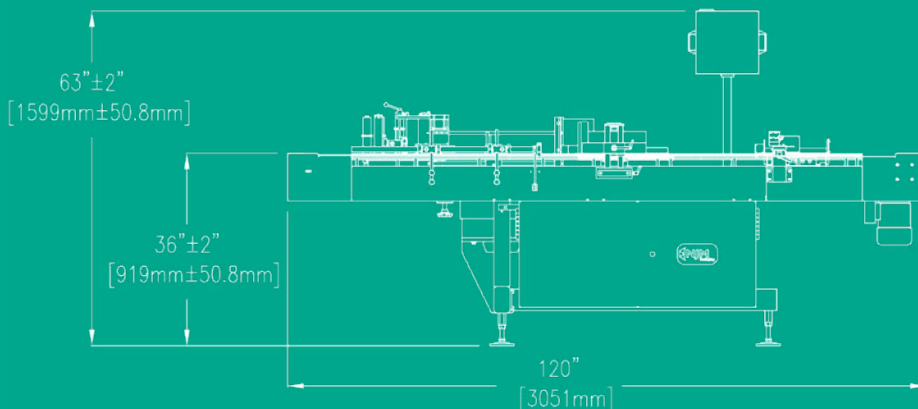
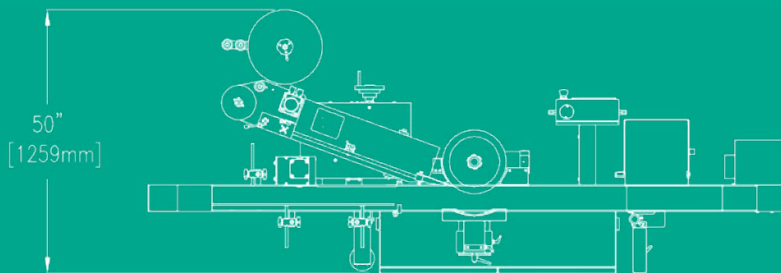

OPTIONS

- Color touch screen HMI control
- Separating Starwheel
- Motorized rewind



SIZE OF LABELS

Length : Min. 1" (25.4 mm), Max. Standard 9" (229 mm), Max. Optional 14" (355 mm)
 Height: Min. 5/8" (16 mm), Max. 7" (178 mm)
 Roll Size: Max. 14" (355 mm) with 3" (76 mm) core diameter

CONTAINER

Diameter: Min. 5/8" (16 mm), Max. Standard 4" (102 mm), Max. Optional 5" (127 mm)
 Height: Min. 1" (25.4 mm), Max. 8" (203 mm)

AIR & ELECTRICAL REQUIREMENTS

Air supply: 80 psi, 1 scfm / Power Supply: 240 VAC, 1 phase, 60 Hz

Dimensions shown are for basic machines and may vary depending on options. In view of our policy of continuing research and product improvement, actual specifications may vary from those shown.

Please consult with an NJM representative regarding your specific requirements.

All NJM equipment is covered by a one year warranty on parts. A comprehensive nationwide service, parts, and sales support program is available for the life of your equipment. A customized Preventative Maintenance Program for this equipment is also available.

This equipment can be purchased separately or as part of a fully integrated packaging line. Contact your sales representative for full details on other packaging equipment and complete turnkey line integration services.